

MAST FURLING MECHANISM

Supplied By; American Rigging Supply, Inc.

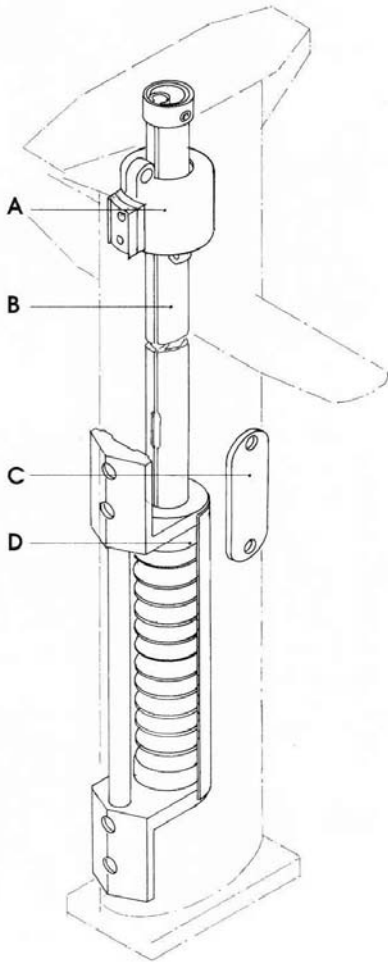

Section	Z 230 E	Z 300 E	Z 400 E	Z 500 E	Z 600 E	Z 700 E	Z 900 E	Z 1100 E	Z 1400 E
B Furling extrusion	Z 55	Z 55	Z 55	Z 55	Z 55	Z 55	Z 55	Z 55	Z 55
A Halyard swivel	3503	3504	3164	3164	3165	3165	3166	3159	3505
D Furling mechanism	3623								
D Furling mechanism with screw		3626	3626	3626	3625	3625	3622	3627	3627
C Maintenance cap	3247	3247	3247	3247	3247	3247	3247	3245	3245
Clew shackle	3208	3208	3208	3208	3208	3208	3208	3208	3208
Halyard swivel shackle	3168	3168	3168	3168	3168	3168	3168	1562	1562