

U.S. SPARS BATTEN CAR SYSTEM

Supplied By American Rigging Supply, Inc.

We have developed a new car system to cope with the special requirements of fully-battened mainsails. The system runs on Torlon ball bearings, with all cars machined from solid aluminium. Track and cars are anodised silver.

	Tracks	Masts	Head Car	Batten Car	Track Ends		Inter Car	Torlon balls	
R 25/1 932		Z 401 Z 531 Z 601 Z 701			3432			4515	29
R 25/2 933		Z 301 Z 395 Z 501			3432		21	4515	29
R 25/3 934		Z 800 E Z 901 Z 900 E Z 1001 Z 1100 E			3432		21	4515	29
R 25/4 931		Z 301 Z 395 Z 501	3482	3481	3432	3483	21	4515	29
R 32 619		Z 1001 Z 1100 E Z 1400	3480	3479	3433		None	4517	77
R 32/1 663		Z 901 Z 1001 Z 1400 Z 1600	3480	3479	3433				

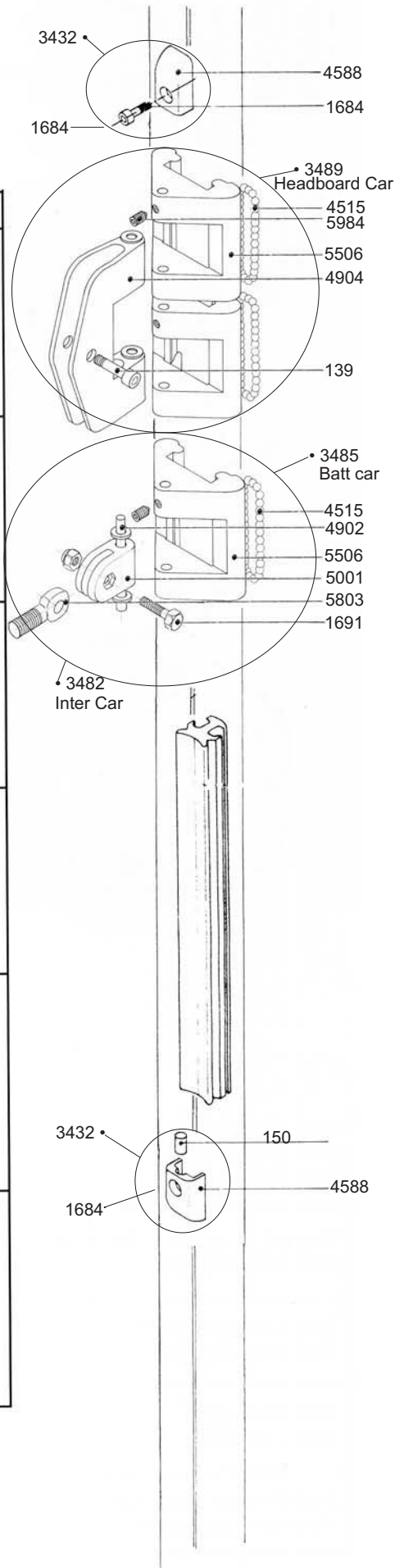

This system comes with a one piece track and is compatible with any U.S. spar mast section.

Ask our sales team for a quotation today.