

ROD JAWS

Rod Jaws (H100) are commonly used as upper and lower terminals on rod backstays, as well as on other low fatigue assemblies such as bobstays.

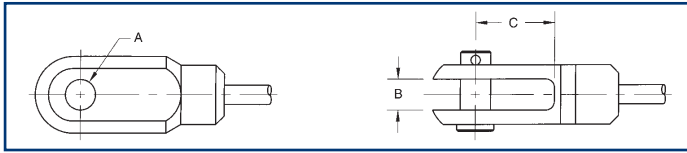

Rod Jaw H100



ROD JAW									
ROD SIZE	PART # STANDARD JAW	AØ		B		C		WEIGHT STD. JAW	
		(in)	(mm)	(in)	(mm)	(in)	(mm)	(lbs)	(grams)
-4	H100-004	0.32	8.1	0.27	6.9	0.79	20.0	0.10	45
-6	H100-006	0.32	8.1	0.33	8.3	0.82	20.8	0.07	32
-8	H100-008	0.39	9.8	0.33	8.3	0.87	22.1	0.20	91
-10	H100-010	0.44	11.1	0.40	10.0	0.90	22.9	0.26	118
-12	H100-012	0.44	11.2	0.46	11.6	1.18	29.8	0.40	182
-17	H100-017	0.52	13.1	0.53	13.5	1.29	32.7	0.55	250
-22	H100-022	0.63	16.0	0.59	15.0	1.48	37.7	1.06	482
-30	H100-030	0.75	19.1	0.65	16.5	1.50	38.0	1.50	682
-40	H100-040	0.88	22.3	0.79	20.1	1.65	41.9	2.34	1063
-48	H100-048	1.01	25.5	0.91	23.1	1.70	43.2	3.31	1504
-60	H100-060	1.145	36.8	1.145	36.8	1.62	41.1	5.00	2272

1. Small Pin Eyes (G150) must be used with H100 and H121 Jaws. G100 Eyes will not fit these jaws.

HIGH FATIGUE JAWS

It is important in forestays to have fittings at each end which permit "toggling" under high load. Forestays are generally highly loaded and the lead angle changes each time the boat tacks. These are severe conditions in terms of fitting and rod fatigue. Fittings designed to minimize bending stresses induced in the rod are essential in this application.

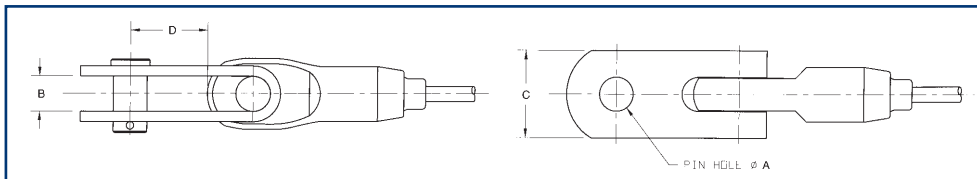

High Fatigue Jaw H200

HIGH FATIGUE JAW											
ROD SIZE	PART NUMBER	AØ		B		C		D		WEIGHT W/STD NOSE	
		(in)	(mm)	(in)	(mm)	(in)	(mm)	(in)	(mm)	(lbs)	(grams)
-4	H200-004	0.375	9.5	0.39	9.8	1.00	25.4	0.94	23.9	0.25	0.11
-6	H200-006	0.438	11.1	0.45	11.4	1.00	25.4	1.04	26.4	0.49	0.22
-8	H200-008	0.500	12.7	0.52	13.2	1.25	31.8	1.02	25.9	0.75	0.34
-10	H200-010	0.500	12.7	0.52	13.2	1.25	31.8	1.39	35.3	0.77	0.35
-12	H200-012	0.625	15.9	0.65	16.4	1.60	40.6	1.43	36.3	1.81	0.82
-17	H200-017	0.625	15.9	0.65	16.5	1.60	40.6	1.43	36.3	1.53	0.69
-22	H200-022	0.750	19.1	0.77	19.6	2.00	50.8	1.74	44.2	2.62	1.19
-30	H200-030	0.875	22.2	0.90	22.7	2.00	50.8	2.16	54.9	3.76	1.71
-40	H200-040	1.000	25.4	1.04	26.4	2.50	63.5	2.53	64.3	5.51	2.50
-48	H200-048	1.125	28.6	1.17	29.6	2.50	63.5	2.82	71.6	7.44	3.37
-60	H200-060	1.250	31.8	1.29	32.8	3.00	76.2	3.41	86.6	11.72	5.32
-76	H200-076	1.250	31.8	1.29	32.8	3.00	76.2	3.41	86.6	13.55	6.15
-91	H200-091	1.375	34.9	1.40	35.4	3.00	76.2	3.90	99.1	17.43	8.25
-115	H200-115	1.560	39.6	1.63	41.4	3.75	95.3	4.23	107.4	26.49	12.01
-150	H200-150	1.750	44.5	1.81	46.1	4.00	101.6	4.75	120.7	37.80	17.14
-170	H200-170	1.875	47.6	1.95	49.4	5.00	127.0	4.75	120.7	38.10	17.28
-195	H200-195	2.125	54.0	2.17	55.0	5.50	139.7	4.75	120.7	N/A	N/A
-220	H200-220	2.250	57.2	2.38	60.5	6.00	152.4	5.00	127.0	N/A	N/A
-260	H200-260	2.438	61.9	2.45	62.3	6.00	152.4	4.10	104.1	94.00	42.63
-320	H200-320	2.500	63.5	2.50	63.5	6.60	167.6	6.00	152.4	N/A	N/A
-400	H200-400	2.500	63.5	2.50	63.5	7.00	177.8	6.75	171.5	N/A	N/A

TANGS

Navtec designs and manufactures standard and custom rigging fittings for all types of yachts from globe circling mega yachts to cruisers and performance racers throughout the world. Navtec answers the need with unsurpassed engineering and in house manufacturing capabilities.



K200 EXTERNAL STEM BALL TANG

The economical K200 Tang has minimal projection inside the mast, a reasonable cut-out size, some projection outside of the mast and can be used with rod or 1 x 19 wire.

GIBB STEM BALL N641 & NAVTEC K200 TANG

SWAGE STEM BALL	ADAPTER WASHER	NAVTEC TANG
N641-04	F400-04-06	K200-006
N641-05	F400-06-06	K200-006
N641-06	N640-06	K200-012
N641-07	N640-07	K200-012
N641-08	N640-08	K200-012
N641-09	N640-08	K200-012
N641-10	F400-17-30	K200-030
N641-12	N640-10	K200-030

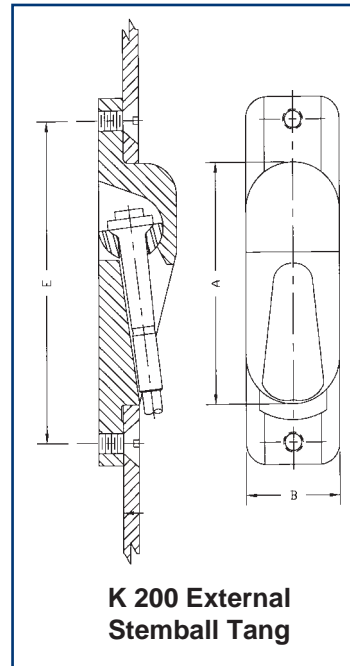

EXTERNAL STEM BALL TANG - ROD, STEM BALL AND SEAT COMBINATIONS

ROD SIZE	TANG PART NUMBER	TAPERED STEM BALL		CUT OUT DIMENSIONS		FASTENER		WEIGHT				
		STEM BALL PART NUMBER	SEAT PART NUMBER	LENGTH (A) (in) (mm)	WIDTH (B) (in) (mm)	LENGTH (E) (in) (mm)	SIZE	(TANG & SEAT) (lbs) (grams)				
-4	K200-006	F220-004	F400-04-06	2.72	69.2	1.13	28.6	3.60	91.4	1/4-20	0.20	91
-6	K200-006	F220-006	F400-06-06	2.72	69.2	1.13	28.6	3.60	91.4	1/4-20	0.20	91
-8	K200-012	F220-008	F400-08-12	3.75	95.3	1.50	38.1	5.05	128.3	5/16-18	0.20	91
-10	K200-012	F220-010	F400-08-12	3.75	95.3	1.50	38.1	5.05	128.3	5/16-18	0.41	186
-12	K200-012	F220-012	F400-12-12	3.75	95.3	1.50	38.1	5.05	128.3	5/16-18	0.41	186
-17	K200-030	F220-017	F400-17-30	5.00	127.0	2.00	50.8	6.70	170.2	3/8-16	1.21	550
-22	K200-030	F220-022	F400-22-30	5.00	127.0	2.00	50.8	6.70	170.2	3/8-16	1.21	550
-30	K200-030	F220-030	F400-30-30	5.00	127.0	2.00	50.8	6.70	170.2	3/8-16	1.21	550
-40	K200-060	F220-040	F400-40-60	6.88	174.6	2.80	71.1	9.40	238.8	5/8-11	2.45	1,113
-48	K200-060	F220-048	F400-48-60	6.88	174.6	2.80	71.1	9.40	238.8	5/8-11	2.45	1,113
-60	K200-060	F220-060	F400-60-60	6.88	174.6	2.80	71.1	9.40	238.8	5/8-11	2.45	1,113
-76	K200-076	F220-076	F400-76-76	9.25	235.0	3.75	95.3	12.50	317.5	3/4-16	7.20	3,272
-91	K200-115	F220-091	F400-91-A2	11.52	292.7	4.50	114.3	15.38	390.7	1-12	N/A	N/A
-115	K200-115	F220-115	F400-A2-A2	11.52	292.7	4.50	114.3	15.38	390.7	1-12	N/A	N/A

STEMBALLS REQUIRE SEPARATE SEATS (F400) FOR USE WITH THESE TANGS.
EXTERNAL STEM BALL TANGS ARE NOT SUITABLE FOR USE WITH MICRO STEM BALLS
K200-060 and up are supplied without fastener holes.
See detailed installation instructions before installing these tangs.

K150 MICRO STEM BALL NAVTANGS

The popularity of the Navtang, due to small mast cut-out, has resulted in the development of the Micro Stemball Navtang with a modification of the original Navtang (now obsolete), allowing the use of Micro Stemballs and K151-02 washers. The Micro Stemball Navtang also uses a stainless steel tie bar instead of an aluminum tie bar.

MICRO STEM BALL NAVTANG

SIZE	TANG PART NUMBER	SHANK DIAMETER (C)		WEIGHT (tang, washer & stemball)	
		(in)	(mm)	(lbs)	(grams)
-4	K150-004	0.75	18.9	0.25	114
-6	K150-006	0.81	20.6	0.33	150
-8	K150-008	0.93	23.6	0.35	159
-10	K150-010	1.00	25.3	0.51	232
-12	K150-012	1.18	30.1	0.71	323
-17	K150-017	1.31	33.1	1.26	573
-22	K150-022	1.49	37.8	1.73	786
-30	K150-030	1.87	47.5	3.12	1,418
-40	K150-040	2.07	52.5	4.37	1,986
-48	K150-048A	2.25	57.1	4.75	2,158
-60	K150-060A	2.63	66.7	5.50	2,499
-76	K150-076	3.00	76.2	7.47	3,394
-91	K150-091	3.25	82.6	9.78*	4,440
-115	K150-115	3.75	95.3	13.74	6,240
-150	K150-150	1.12	28.4	19.32	8,780

Mast o.d. (dimension D in sketch) must be specified when ordering. When Navtangs are installed, as shown, without a compression tube, a stainless steel protective sleeve should be used to protect the tie bar from halyard chafe. Micro Navtang part numbers are for a complete assembly including cap, micro stemball, washer and tie bar. The Micro Navtang is made from 316 stainless steel.

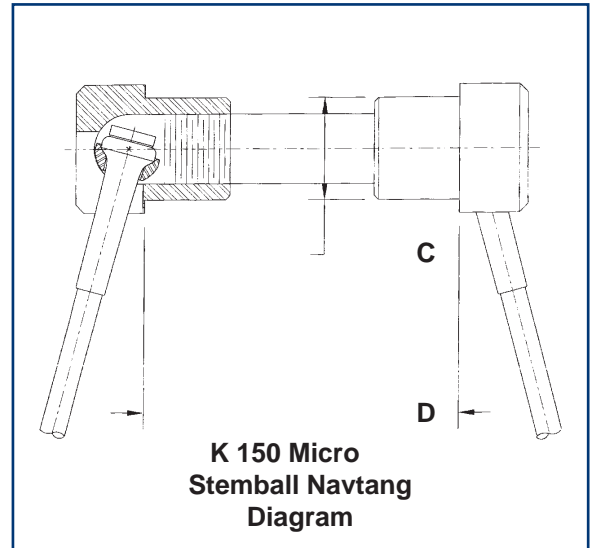

K550 SCREW IN TANGS

Developed from America's Cup tangs, these tangs offer a lightweight alternative to the K150 tang where no tie bar is desired. The height of the sleeve on the backing plate is specified to match mast wall thickness, thus creating a custom fit for every mast. This feature makes the K550 an excellent choice for Carbon masts as well as Aluminum.

With the cap made from high strength stainless alloy and the backing plate made from 316 stainless, corrosion life of the K550 is unsurpassed.

K550 SCREW IN TANG

ROD SIZE	TANG PART NUMBER	SCREW SIZE		MAST HOLE Ø		D		WEIGHT	
		(in)	(mm)	(in)	(mm)	(in)	(mm)	(lb)	(kg)
-6	K550-006-01	1/4	20	1.25	4.7	2.25	57.2	0.34	0.15
-8	K550-008-01	1/4	20	1.25	4.7	2.25	57.2	0.34	0.15
-10	K550-010-01	1/4	20	1.38	3.9	2.75	69.9	0.4	0.19
-12	K550-012-01	1/4	20	1.38	3.9	2.75	69.9	0.4	0.19
-17	K550-017-01	5/16	18	1.88	5.5	3.75	95.3	1.1	0.48
-22	K550-022-01	5/16	18	1.88	5.5	3.75	95.3	1.1	0.48
-30	K550-030-01	3/8	16	2.19	6.1	4.25	108.0	1.7	0.77
-40	K550-040-01	7/16	20	2.50	8.4	4.75	120.7	2.6	1.16
-48	K550-048-01	7/16	20	3.00	10.4	5.25	133.5	2.6	1.16
-60	K550-060-01	1/2	13	3.13	9.9	6.00	152.4	5.2	2.34
-76	K550-076-01	5/8	11	3.63	8.5	6.95	175.5	6.6	3.00
-91	K550-091-01	5/8	11	4.13	14.2	7.50	190.5	7.8	3.54
-115	K550-115-01	3/4	10	4.75	17.8	8.50	215.9	11.0	5.00
-150	K550-150-01	7/8	9	5.13	20.1	10.00	254.0	15.0	6.82

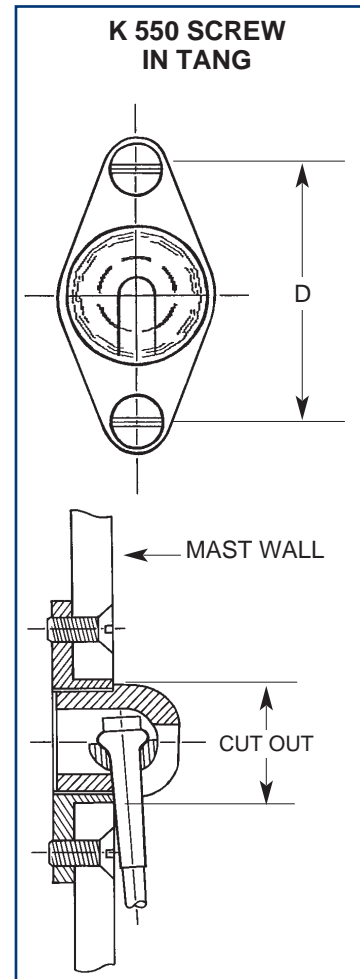

SPREADER TIP CUPS

Navtec has developed a comprehensive range of performance spreader tips designed to suit a wide range of sailing applications. Developed over many seasons, each has been optimized to offer a particular performance advantage. Finite Element Analysis (F.E.A.) modeling is used to help optimise the tip cups for weight reduction and long fatigue life.

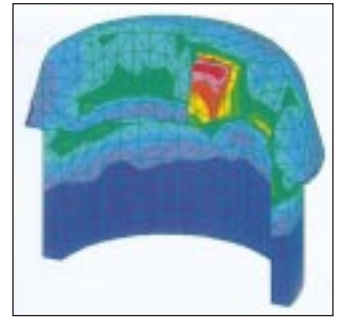

L500 TIP CUPS

The L500 is the latest in Navtec's line of spreader end tip cups. The L500 incorporates Navtec's F235 Micro stemballs to provide superior fatigue resistance. They feature the same anti-rotational lock pin developed for the L528 range of tip cups and fit completely inside the spreader, significantly reducing sail chafe. The L500 is made from three parts, a body, a plug, and a locking nut to make installation easier. The part numbers for the L500 include all the information on rod sizes, diagonal ports and angles to allow the mast maker and riggers to choose the correct tip cup. See table below for more information on part numbers. The hole cutouts have been standardized throughout the line to allow the mast maker to build the spreader ends accurately once the rod sizes are determined.

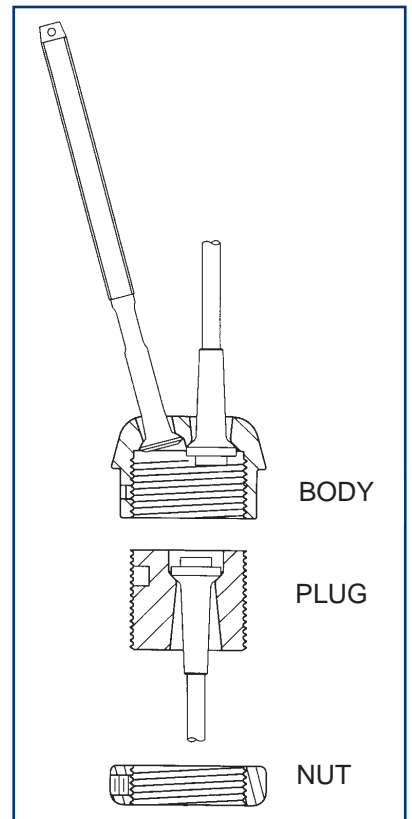
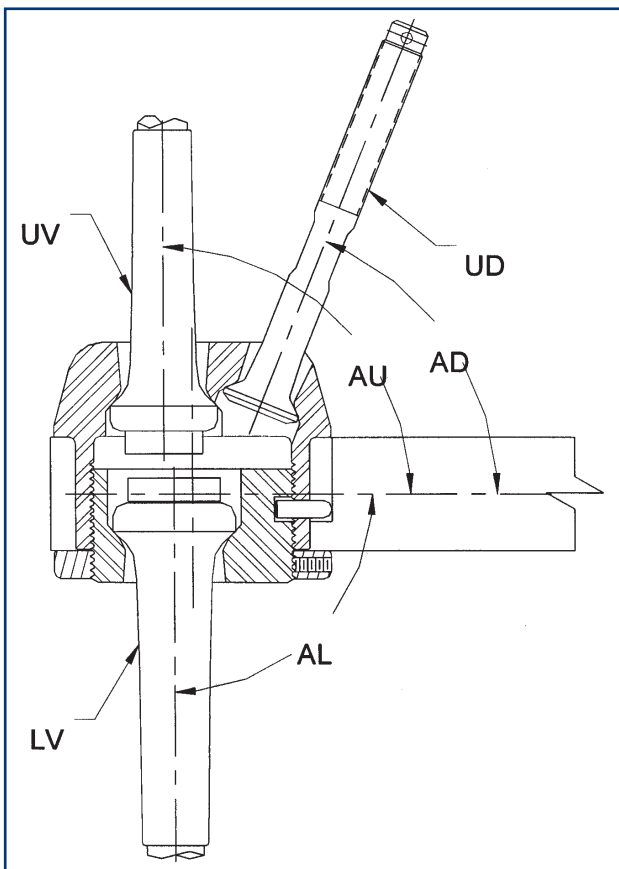

L500 TIP CUP ANGLES AND PART NUMBERING

Part numbers for the L500 tip cup are as follows:-

L500-LV/UV/UD/SN

Where:

- LV = Lower Vertical Dash Size
- UV = Upper Vertical Dash Size
- UD = Upper Diagonal Screw Size in 32nds of an inch
- SN = Serial Number corresponding to the angle combinations shown below

If you are unsure about what to order, or if angles are still in question please forward rod sizes and angles to NAVTEC sales for the correct part numbering.

SN	AL	AU	AD
01	87° ±5°	90° ±5°	75° ±5°
02	89° ±5°	90° ±5°	80° ±5°
03	87° ±5°	90° ±5°	70° ±5°
04	90° ±5°	90° ±5°	75° ±5°
05	90° ±5°	90° ±5°	80° ±5°
06	90° ±5°	90° ±5°	70° ±5°
07	84° ±5°	90° ±5°	75° ±5°
08	84° ±5°	90° ±5°	80° ±5°
09	84° ±5°	90° ±5°	70° ±5°
10	ANY	ANY	ANY

L400 TIP CUP

Designed for “smaller” boats, the L400 spreader tip is a two-piece modular design for economy and flexibility. The body and plug are designed to accept 75 different rod combinations! Combinations available for:-

Lowers: -4, -6, -8, -10, -12
Uppers: -4, -6, -8, -10, -12
Diagonal: -4, -6, -8

Standardized for manufacturing economy, interchangeable seats are used for each rod size. Currently being used on many 30' designs, these tip cups make modern discontinuous rigging affordable for boats from 24-36 feet.

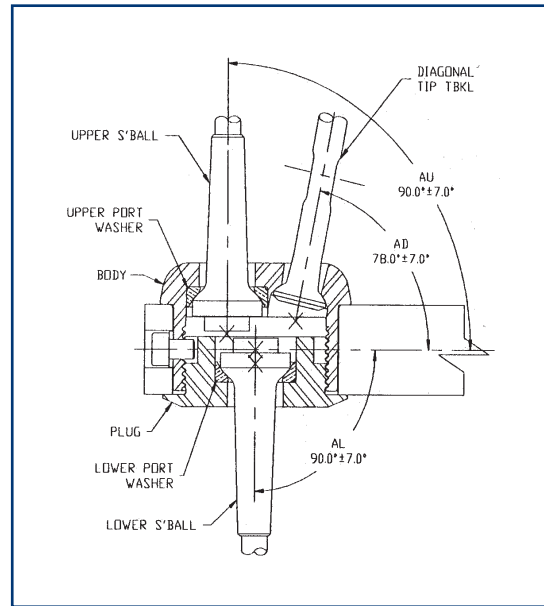

GRAND PRIX TIP CUPS

L834 MICRO TIP CUP

The L834 Micro Tip is made from ultra high strength stainless steel to reduce overall size and weight. The L834 Tip Cup is the choice of top IMS Grand Prix racers from the Maxi level down. Each Micro Tip Cup is engineered to minimize weight and size for each boats specific application.

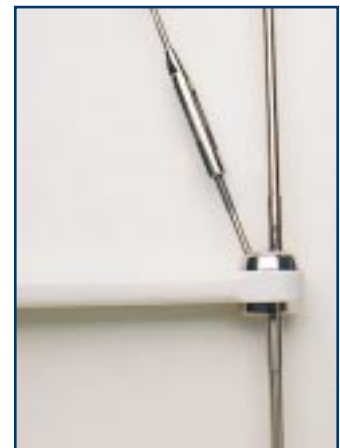

L900 ALLOY TIP CUP

The L900 is the latest in Navtec's line of performance tip cups. The L900 Tip cup is made from high strength aluminum alloys to optimize weight. The L900 offers up to 50% weight savings over its comparable stainless steel counterparts. Developed for the 1998 Admiral's Cup winner Flash Gordon, they have become the standard on the IMS Grand Prix circuit. The L900 requires a little more care in handling and assembly, and requires routine inspection.



CUSTOM TIP CUPS

Navtec has many years of experience designing Tip Cups. Through the years Navtec has designed many custom Tip Cups from ILC 30's to our present line of titanium no stemball America's Cup range. Navtec engineers are constantly testing new designs incorporating new materials to stay on the leading edge of racing and Superyacht mast requirements. Please contact Navtec for more details.

TIP TURNBUCKLES

Tip Turnbuckles are the lightest method of adjusting small rod lengths, such as diagonal shrouds. Our range has been developed to offer accurate calibration, and are manufactured in a range of metals to suit your performance requirement.

C651 CHROME BRONZE

The C651 Tip Turnbuckle has a chrome-plated bronze body and high strength stainless ballhead screw. Adaptor washers (D342-T) may be required if a smaller diagonal rod size is used other than that specified in standard Tip Cups.



C880 NITRONIC 50

The C880 Tip Turnbuckle is part of Navtec's Series 800 IMS range. It offers weight savings comparable to the C780, but without the use of titanium.



C882 IN-LINE TURNBUCKLE

The C882 In-Line Turnbuckle is used on jumpers in place of a long screw tip turnbuckle. The center screw design allows for greater loads to be generated as is required in ILC yachts. This design also allows a smaller tang to be used than the tip turnbuckle system requires.



C651 BRONZE BODY TIP TURNBUCKLE

ROD SIZE	PART#	PORT SIZE (No adapter required ¹)	THREAD DIAM.		STROKE		BREAKING STRENGTH		WEIGHT	
			(in)	(mm)	(in)	(mm)	(lbs)	(kgs)	(lbs)	(grams)
-4	C651-004-08	D341-08	1/4	6.40	2.0	51	6200	2818	0.18	82
	C651-004-10	D341-10	5/16	8.00	2.2	56	10000	4545	0.38	172
-6	C651-006-10	D341-10	5/16	7.9	2.2	56	1000	4545	0.38	172
-8	C651-008-10	D341-10	5/16	7.9	2.2	56	13500	6136	0.38	172
-10	C651-010-12	D341-12	3/8	9.5	2.5	64	13500	6136	0.52	236
-12	C651-012-15	D341-14	7/16	11	2.8	71	20500	9318	0.84	381
-15	C651-014-16	D341-16	1/2	13	3.0	76	28000	12727	1.23	558
-17	C651-017-16	D341-16	1/2	13	3.0	76	28,000	12727	1.23	558
-22	C651-022-20	D341-20	5/8	16	3.6	91	41000	18636	2.08	943
-30	C651-030-20	D341-20	5/8	16	3.6	91	41000	18636	2.68	1215
-40	C651-402428A	D341-24	3/4	19.1	3.9	99	70000	31818	4.69	2127
-48	C651-482428B	D341-24	3/4	19.1	3.9	99	70000	31818	4.66	2113
-60	C651-602832B	D341-28	7/8	22.2	4.2	107	96000	43636	6.11	2771

1. Adaptor washers are required when a tip turnbuckle is used in a port larger than the indicated standard port.

C880 TIP TURNBUCKLE

ROD SIZE	PART#	PORT SIZE (No adapter required ¹)	THREAD DIAM.		STROKE		BREAKING STRENGTH		WEIGHT	
			(in)	(mm)	(in)	(mm)	(lbs)	(kgs)	(lbs)	(grams)
-6	C880-006-10	D341-10	5/16	7.9	1.9	48	10000	4545	0.27	122
-8	C880-008-10	D341-10	5/16	7.9	1.9	48	10000	4545	0.27	122
-10	C880-010-12	D341-12	3/8	9.5	2.0	51	13500	6136	0.39	177
-12	C880-012-14	D341-14	7/16	11.0	2.0	51	13500	6136	0.54	245
-15	C880-015-16	D341-16	1/2	0.5	2.1	53				
-17	C880-017-16	D341-16	1/2	13.0	2.1	53	28000	12727	0.72	327
-22	C880-022-20	D341-20	5/8	16.0	2.9	74	41000	18636	1.40	635
-30	C880-030-20	D341-20	5/8	16.0	3.2	80	41000	18636	1.49	676
-40	C880-402428	D341-24	3/4	19.0	3.7	94	70000	31818	2.47	1120
-48	C880-482428	D341-24	3/4	19.0	3.7	94	70000	31818	2.88	1306
-60	C880-602832	D341-28	7/8	22.0	4.0	102	96000	43636	4.81	2182

1. Adaptor washers are required when a tip turnbuckle is used in a port larger than the indicated standard port.

C882 IN-LINE TURNBUCKLE

ROD SIZE	PART #	LENGTH				THREAD DIAM.	WEIGHT	
		OPEN (in)	OPEN (mm)	CLOSED (in)	CLOSED (mm)		(lbs)	(kg)
-4	C882-004L08	12.46	316.5	9.00	228.6	1/4 - 28	0.26	0.12
-6	C882-006L10	13.11	333.0	9.33	237.0	5/16 - 24	0.54	0.25
-8	C882-008L10	13.11	333.0	9.33	237.0	5/16 - 24	0.54	0.25
-10	C882-010L12	14.36	364.7	10.24	260.1	3/8 - 24	0.66	0.30
-12	C882-012L14	14.64	371.9	10.84	275.3	7/16 - 20	0.93	0.42
-15	C882-015L16	14.80	375.9	10.30	261.6	1/2 - 20	1.14	0.52
-17	C882-017L16	14.80	375.9	10.30	261.6	12/2 - 20	1.14	0.52
-22	C882-022L20	19.05	483.9	13.16	334.3	5/8 - 18	1.96	0.89
-30	C882-030L20	19.71	500.6	13.39	340.1	5/8 - 18	2.33	1.06
-40	C882-040L24	23.25	590.6	15.75	400.1	3/4 - 16	3.96	1.80
-48	C882-048L24	23.91	607.3	16.41	416.8	3/4 - 16	4.59	2.08
-60	C882-060L23	25.77	654.6	17.77	451.4	7/8 - 14	8.20	3.72

TURNBUCKLES - ROD & WIRE RIGGING

NAVTEC SERIES 500

Designed for strength and reliability, the 500 series is available for both rod and wire rigging. The 500 Series is made from 316 stainless steel and has the following features:-

C550 TURNBUCKLES FOR ROD

- Center screw design allows for easy adjustment under high load.
- The bronze center screw is nickel plated, which not only looks good but also provides lubricity to prevent galling.
- Available for -4 to -400. For turnbuckles -76 and larger, Navtec uses highly polished stainless steel bodies with bronze thread inserts to resist galling and high strength stainless screws to decrease the overall size and weight.
- The C560 prefix represents the marine eye version.
- Long Screw option available.

C500 TURNBUCKLES FOR WIRE

- The swage end, made from 316 stainless, is drilled through to allow the rigger to fully insert the wire before swaging and to allow water to drain from the fitting.
- The Series 500 Turnbuckles can be fitted with an extra long screw in the event the swage end has to be replaced or if the rigging is otherwise too short.
- C500 prefix designates the toggle end version, and the C510 represents the marine eye version .

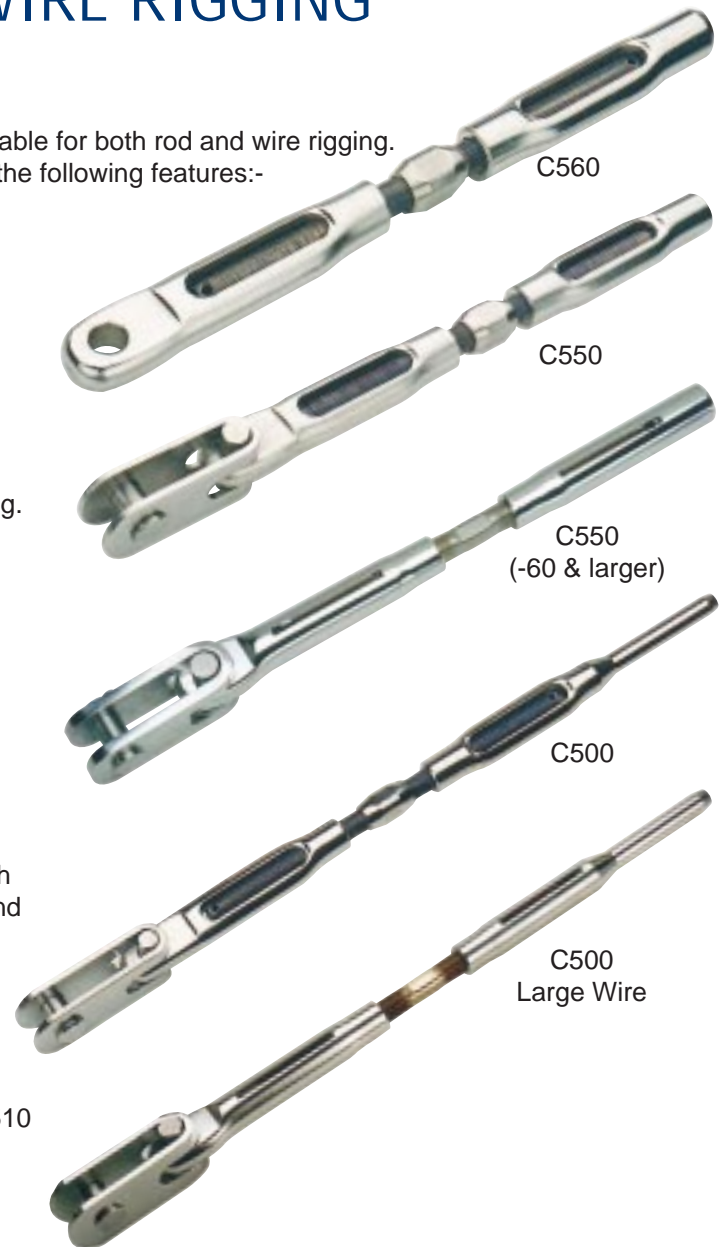

ALSO SEE NORSEMAN ROD TURNBUCKLES ON PAGE 10

RIGGING SPARES & ACCESSORIES

Navtec offers a full range of spare rigging parts. They include Standard Screws (D-320-S), Long Screws (D-320-L), Series 500 Rod Bodies, Series 500 Swage Ends, Jaw/Jaw Toggles, Eye/Jaw Toggles, Series 500 Eye Ends with Toggle and Clevis Pins.

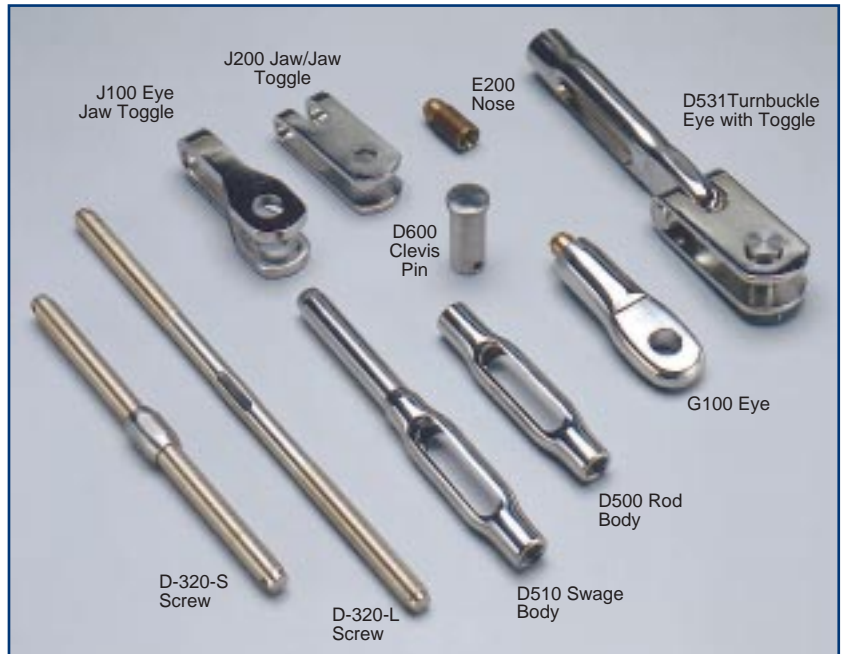

SERIES 500 TURNBUCKLE

ROD SIZE	PART NUMBER	THREAD DIAM.		PIN DIAM.		LENGTH OPEN (1)		LENGTH CLOSED (1)		WEIGHT	
		(in)	(mm)	(in)	(mm)	(in)	(mm)	(in)	(mm)	(lbs)	(kg)
STANDARD TURNBUCKLES											
-4	C550-041012	5/16	7.9	3/8	9.5	12.35	314	8.53	217	0.47	0.21
-6	C550-061214	3/8	9.5	7/16	11.1	13.82	351	9.66	245	0.70	0.32
-8	C550-081416	7/16	11.1	1/2	12.7	15.13	384	10.43	265	1.25	0.57
-10	C550-101616	1/2	12.7	1/2	12.7	17.33	440	12.25	311	1.66	0.75
-12	C550-121620	1/2	12.7	5/8	15.9	18.62	473	13.00	344	1.72	0.78
-17	C550-172020	5/8	15.9	5/8	15.9	20.15	512	14.09	358	3.19	1.45
-22	C550-222424	3/4	19.1	3/4	19.1	23.85	606	17.37	441	5.51	2.50
-30	C550-302828	7/8	22.2	7/8	22.2	26.98	685	19.77	502	8.50	3.85
-40	C550-403232	1	25.4	1	25.4	29.26	743	21.65	550	11.50	5.22
-48	C550-483636	1 1/8	28.6	1 1/8	28.6	30.47	774	22.85	580	14.69	6.66
-60	C550-604040	1 1/4	31.8	1 1/4	31.8	32.80	883	24.98	634	22.90	10.39
-76	C550-763640A	1 1/8	28.6	1 1/4	31.8	34.12	867	25.13	638	24.33	11.03
-91	C550-914044A	1 3/8	34.9	1 1/4	31.8	40.10	1019	27.72	704	34.25	15.53
-115	C550-A24450	1 3/8	34.9	1 9/16	39.7	44.32	1126	30.74	781	44.90	20.36
-150	C550-A55256A	1 1/2	38.1	1 3/4	44.5	47.87	1216	31.29	795	73.00	33.11
-170	C550-A75260A	1 5/8	41.3	1 7/8	47.6	52.14	1324	37.14	943	82.00	37.19
-195	C550-A96068A	1 7/8	47.6	2 1/8	54.0	54.98	1396	37.20	945	106.00	48.07
-220	C550-B26072	1 7/8	47.6	2 1/4	57.2	65.23	1657	47.43	1205	139.00	63.05
-260	C550-B67678	2 3/8	60.3	2 7/16	61.9	57.80	1468	41.70	1059	178.00	80.73
-320	C550-C28084	2 1/2	63.5	2 5/8	66.7	58.00	1473	41.50	1054	220.00	99.80
-400	C550-D08480	2 5/8	66.7	2 1/2	63.5	58.72	1491	41.22	1047	265.00	120.18

1. Length based on pin center line to rod head.

COMMON REPLACEMENT PARTS

D510 SWAGE BODIES

PART NUMBER	WIRE DIAMETER (in)	THREAD DIAMETER (in)
D510-0510	5/32	5/16
D510-0610	3/16	5/16
D510-0612	3/16	3/8
D510-0710	7/32	5/16
D510-0712	7/32	3/8
D510-0714	7/32	7/16
D510-0812	1/4	3/8
D510-0814	1/4	7/16
D510-0816	1/4	1/2
D510-0914	9/32	7/16
D510-0916	9/32	1/2
D510-1016	5/16	1/2
D510-1020	5/16	5/8
D510-1220	3/8	5/8
D510-1424	7/16	3/4
D510-1628	1/2	7/8
D510-1828	9/16	7/8
D510-2032	5/8	1
D510-2440	3/4	1 1/4
D510-2844	7/8	1 3/8

D531 LH TURNBUCKLE EYE WITH TOGGLE

PART NUMBER	THREAD DIAMETER (in)	PIN DIAMETER (in)
D531-0808	1/4	1/4
D531-0810	1/4	5/16
D531-1010	5/16	5/16
D531-1012	5/16	3/8
D531-1212	3/8	3/8
D531-1214	3/8	7/16
D531-1414	7/16	7/16
D531-1416	7/16	1/2
D531-1616	1/2	1/2
D531-1620	1/2	6/8
D531-2020	5/8	5/8
D531-2424	3/4	3/4
D531-2828	7/8	7/8
D531-3232	1	1
D531-3632	1 1/8	1
D531-3636	1 1/8	1 1/8
D531-4040	1 1/4	1 1/4

RIG-RAP

Navtec's Rig-Rap rigging tape stretches to twice its length and sticks only to itself. It conforms easily to any turnbuckle or spreader tip fitting. Rig-Rap does not deteriorate in sunlight or salt water and will protect expensive sails from sharp edges.

Roll is 36' x 1". Part number: V100-01 (1 Roll), V100-02 (1 Case of 24 rolls).



SERIES 890 TURNBUCKLES ADJUSTABLE BARREL PIN TERMINALS

These are the ultimate lightweight turnbuckle. These were born from the America's Cup and are now on the top ILC's, One Design classes and all of the new generation Maxi's. GP Terminals are calibrated for accurate tuning and are made from highly polished Nitronic 50.



C890 ADJUSTABLE BARREL PIN TERMINAL													
ROD SIZE	PART NUMBER	PIN SIZE		ROD STRENGTH		TERMINAL STRENGTH		LENGTH OPEN		LENGTH CLOSED		WEIGHT	
		(in)	(mm)	(lbs)	(kg)	(lbs)	(kg)	(in)	(mm)	(in)	(mm)	(lbs)	(kgs)
-10	C890-BP10001	1/2	12.7	10300	261620	14900	378460	8.11	205.994	6.11	155.194	0.73	18.542
-12	C890-BP12001	5/8	15.9	12500	317500	17880	454152	8.11	205.994	6.11	155.194	0.73	18.542
-15	C890-BP-15001	5/8	15.9	14250	361950	26520	673608	8.11	205.994	6.11	155.194	0.76	19.304
-17	C890-BP-17001	5/8	15.9	17500	444500	26520	673608	8.11	205.994	6.11	155.194	0.76	19.304
-22	C890-BP-22001	3/4	19.1	22500	571500	41290	1048766	9.007	228.7778	7.007	177.9778	1.49	37.846
-30	C890-BP-30001	7/8	22.2	30000	762000	44960	1141984	9.32	236.728	7.32	185.928	2.038	51.7652
-40	C890-BP-40001	1	25.4	36000	914400	72410	1839214	10.75	273.05	8.75	222.25	2.89	73.406
-48	C890-BP-48001	1 1/8	28.6	46000	1168400	72410	1839214	12.09	307.086	9.59	243.586	3.932	99.8728
-60	C890-BP-60001	1 1/4	31.8	59000	1498600	99350	2523490	20.31	515.874	16.81	526.974	10.43	264.922
-76	C890-BP-76001	1 1/4	31.8	76000	1930400	129290	3283966						
-91	C890-BP-91001	1 3/8	34.9	90000	2286000	166000	4216400						

SERIES 800 TURNBUCKLE - CALIBRATED

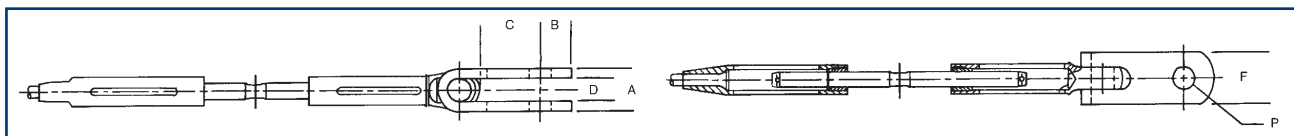

SERIES 800 TURNBUCKLE DIMENSIONS													
ROD SIZE	PART NUMBER	(in)	P (mm)	(in)	A (mm)	(in)	B (mm)	(in)	C (mm)	(in)	D (mm)	(in)	F (mm)
-8	C800-081014	0.5	12.7	0.82	20.828	0.7	17.78	1.12	28.448	0.45	11.43	1.13	28.702
-10	C800-101216	1/2	12.7	0.90	22.86	0.78	19.812	1.46	37.084	0.52	13.208	1.25	31.75
-12	C800-121420	5/8	15.875	1.02	25.908	0.84	21.336	1.46	37.084	0.52	13.208	1.38	35.052
-15	C800-151620	5/8	15.875	1.02	25.908	0.93	23.622	1.54	39.116	0.65	16.51	1.6	40.64
-17	C800-171620	5/8	15.875	1.02	25.908	0.93	23.622	1.54	39.116	0.65	16.51	1.6	40.64
-22	C800-222024	3/4	19.05	1.27	32.258	1.19	30.226	1.69	42.926	0.77	19.558	2	50.8
-30	C800-302028	7/8	22.225	1.68	42.672	1.19	30.226	2.14	54.356	0.88	22.352	2	50.8
-40	C800-402432	1	25.4	1.79	45.466	1.45	36.83	2.54	64.516	1.04	26.416	2.5	63.5
-48	C800-482436	1 1/8	28.575	2.17	55.118	1.45	36.83	2.78	70.612	1.17	29.718	2.5	63.5
-60	C800-602840	1 1/4	31.785	2.29	58.166	1.82	46.228	3.62	91.948	1.29	32.766	3	76.2
-76	C800-763240L	1 1/4	31.75	2.29	58.166	1.82	46.228	3.50	88.9	1.29	32.766	3	76.2
-91	C800-913644L	1 3/8	34.925	2.65	76.31	1.82	46.228	3.80	96.51	1.4	35.56	3	76.2
-115	C800-A24450L	1 9/16	39.6875	2.88	73.152	2.25	57.15	4.16	105.664	1.63	41.402	3.75	95.25
-150	C800-A55256L	1 3/4	44.45	3.31	84.074	2.43	61.722	4.52	114.808	1.81	45.974	4	101.6
-170	C800-A75660L	1 7/8	47.625	3.42	86.868	3.13	79.502	4.63	117.602	1.92	48.768	5	127
-195	C800-A96068L	2 1/8	53.975	3.67	93.218	3.35	85.09	4.80	121.92	2.17	55.118	5.5	139.7
-220	C800-B26472L	2 1/4	57.15	3.86	98.044	3.70	93.98	5.12	130.048	2.38	60.452	6	152.4
-260	C800-B67678L	2 7/16	61.9125	4.45	113.03	3.50	88.9	4.27	108.458	2.45	62.23	6	152.4

NORSEMAN ROD STUDS

NEW PRODUCT



These rod studs were developed to have the same distinguished styling as Norseman Swageless Terminals. Designed to be used with our 674 Turnbuckles (see page 18), they provide the most economical way to rig a boat with rod.

Available in sizes from -04 to -22.

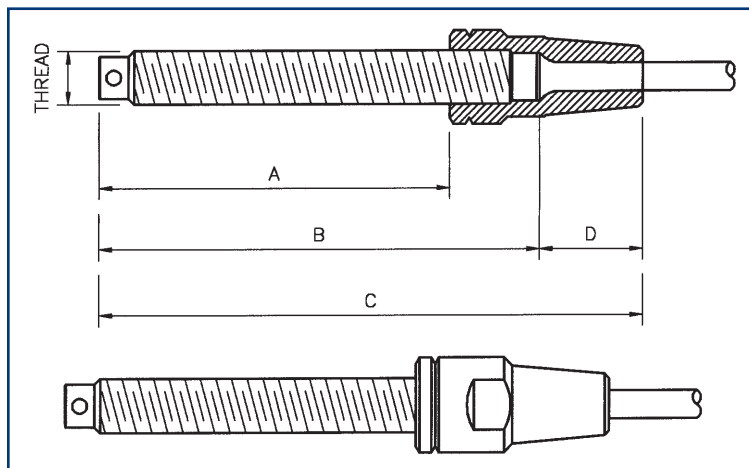

NORSEMAN ROD STUD

METRIC DIMENSIONS

PART #	ROD Ø	THREAD	A	B	C	D	674 C/L PIN TO ROD SEAT			RIGGING SCREW WEIGHT
							OPEN	CLOSED	STROKE	
N90-004-3/8	-4	(UNF) 3/8	(mm) 66	(mm) 84	(mm) 99	(mm) 17	(mm) 292	(mm) 203	(mm) 89	(kg) 0.27
N90-006-7/16	-6	7/16	74	94	114	20	330	229	102	0.40
N90-008-7/16	-8	7/16	74	94	114	20	330	229	102	0.40
N90-008-1/2	-8	1/2	84	104	130	25	381	279	102	0.71
N90-010-1/2	-10	1/2	84	104	130	25	381	279	102	0.71
N90-012-1/2	-12	1/2	84	104	130	25	381	279	102	0.71
N90-012-5/8	-12	5/8	102	127	155	28	457	330	127	1.27
N90-017-5/8	-17	5/8	102	127	155	28	457	330	127	1.27
N90-022-3/4	-22	3/4	114	145	179	33	521	381	140	2.23

USA - IMPERIAL DIMENSIONS

PART #	ROD Ø	THREAD	A	B	C	D	N690 C/L PIN TO ROD SEAT			RIGGING SCREW WEIGHT
							OPEN	CLOSED	STROKE	
N090-0412	-4	(in) 3/8 - 24	(in) 2.6	(in) 3.3	(in) 3.9	(in) .65	(in) 11.5	(in) 8	(in) 3.5	(lb) .59
N090-0614	-6	7/16 - 20	2.9	3.7	4.5	.80	13	9	4	.87
N090-0814	-8	7/16 - 20	2.9	3.7	4.5	.80	13	9	4	.87
N090-0816	08	1/2 - 20	3.3	4.1	5.1	1.00	15	11	4	1.57
N090-1016	-10	1/2 - 20	3.3	4.1	5.1	1.00	15	11	4	1.57
N090-1216	-12	1/2 - 20	3.3	4.1	5.1	1.00	15	11	4	1.57
N090-1220	-12	5/8 - 18	4.0	5.0	6.1	1.10	18	13	5	2.80
N090-1720	-17	5/8 - 18	4.0	5.0	6.1	1.10	18	13	5	2.80
N090-2224	-22	3/4 - 16	4.5	5.7	7.0	1.30	20.5	15	5.5	4.90

N090 screwed into an N674 = N690 Turnbuckle
See price sheet for listing of N690 Turnbuckle