

Supplied By; American Rigging Supply, Inc.

Edson Ultra-Light Racing System™

Designed and built in cooperation with the most respected performance yacht builders in the world, the Ultra-Light Racing System is an extremely lightweight and strong steering system for the modern racing yacht. Edson's engineers have optimized the design of the Radial Drive, Steering Wheel, Steering Drum and Line System to achieve a remarkable strength-to-weight ratio. Race-proven in numerous ILC, IMS, IRM and One-Design Winners, the Edson ULRS's combination of Large-Diameter Steerer, Ultra-Light or Carbon Wheels and Lightweight Radial Drive makes it the lightest, strongest, FASTEST steering system available today.

ULRS Features

- Total system weighs as little as 28 Pounds including wheel!
- Utilizes 5/16" Vectran® Line for Strength, Weight Savings and Low Stretch.
- Large Diameter Hollow Drum Hub & Shaft for Load Distribution and Weight Savings.
- Engineered Wheel Spoke Pattern to Optimize Strength and Add To Lightness.
- Super-Lightweight "Butterfly" Radial Wheel.



Farr 40



Featured On:



Edson specifies, designs and builds a large variety of Custom and Semi-Custom Steering Systems and Wheels for Racing and Cruising Yachts. If you are building a custom boat, contact Edson Customer Service at 508-995-9711. By being involved in the earliest stages of planning, Edson's Design Team can work with you, your designer, captain, builder or project manager to streamline the steering and provide the optimum system for your boat.

Multi-Mode Steerer

Edson's Multi-Mode Steerer was developed for larger yachts to have the helm feel and sensitivity that are usually found in smaller performance boats. Three steering modes are available: a lower gear ratio for increased steering control in heavy weather when steering loads are high, a higher gear ratio for maneuvering at lower speeds such as docking, navigating a narrow channel while under power or sailing in lighter air, and a "Neutral" gear that disengages the wheel while under autopilot.

Multi-Mode Steerer - Contact Edson Customer Service for Ordering Information.



Rick Tomlinson photo

Vitters 180 ADELE

SPEED-STEER™ Multi-Mode Steerer

After building a number of successful Multi-Mode steering arrangements designed for larger vessels, Edson is bringing this innovative steering concept to a more compact size for smaller boats.

Sized for yachts in the 50' to 80' range, this new steerer expands the benefits of the Multi-Mode concept used in MegaYachts to a greater range of boats. As with the larger Multi-Mode Steerers, the SPEED-STEER™ offers multiple 'speeds' to provide critical helm feel and sensitivity over a broad range of conditions: From racing to cruising, light air to heavy weather, docking to passagemaking, parents to children.

SPEED-STEER™ Multi-Mode Steerer - Contact Edson Customer Service for Ordering Information.

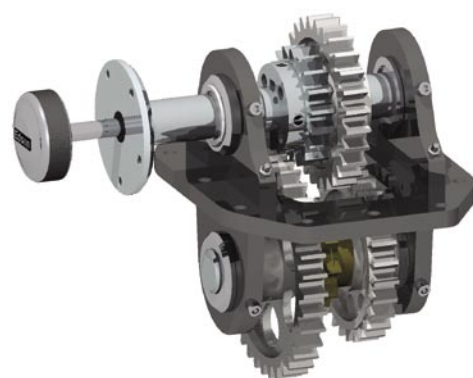

Edson Rudder Bearings are designed and built to the highest standards. Edson's innovative new bearings are available in aluminum, stainless steel or polymer and feature precision machined Ertalylite™ rollers that are completely stable in underwater applications. All Bearings feature pop-out roller bearings allowing for easy disassembly and maintenance.

Serviceable

Edson Bearings have unique "Snap-in" Roller design making maintenance Quick & Easy.

Smooth

Edson Bearings use large diameter Ertalylite™ Rollers reducing friction while increasing load capacity.

Rugged

Edson Bearings are built to last with 3-times more Hard-coat Anodizing as found on other bearings.



Upper Flanged Bearing

Lower Bearing



GO TO

Visit www.edsonmarine.com for further information and to request Edson's Rudder Bearing Worksheet, or contact our Rudder Bearing Specialist to discuss your particular requirements.

Edson's Distinctive Yacht Wheels Catalog



For 147 years, Edson wheels have graced many of the world's finest yachts. Now for the first time, those wheels are featured together in an all-new catalog, Edson's *Distinctive Yacht Wheels*. The 28-page brochure showcases Edson's full line of wheels for both power and sail, designed to fit not only Edson Steering Systems, but those built by other manufacturers as well. Featuring wheels for boats of all types, from Megayachts to Tenders, Sportfish to Flats Boats, Coastal Cruisers to Round the World Voyagers, the new catalog shows every wheel in the Edson line, along with photos of many of the yachts on which they have become the focal point. Edson wheels are handmade by master craftsmen with exotic materials including carbon fiber, marine alloys, teak, holly and other hardwoods.

Call or visit www.edsonwheels.com for your copy.