

Bômes

& options

Booms









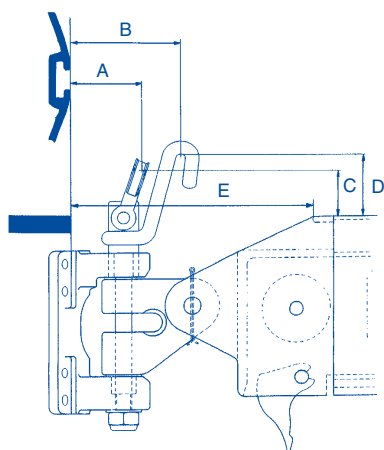

Bômes & options de bômes / Booms & option booms

Standards ou sur mesure, aluminium ou composite, classiques ou motorisées, les bômes Sparcraft sont optimisées pour votre bateau, grâce aux nombreuses adaptations possibles. Leur conception, leur fabrication et les astuces acquises grâce à notre expérience faciliteront vos manœuvres en mer.

 Standard or custom, aluminium or composite, traditional or motorized, the Sparcraft booms are optimized for your boat. Their design, manufacturer and ease of operation thanks to our experience, will be appreciate under sail.



	Dimensions (en mm)	IXX' (Cm4)	IYY' (Cm4)	Poids (Kg/M) Weight
	52 x71,6	15	32	1,34
	68 x95	42	90	2,1
	80 x110	70	165	2,5
	98 x130	143	340	3,72
	98 x160	200	620	4,70
	121 x190	360	1000	5,44
	122 x225	460	1793	6,95
	130 x276	725	3280	8,71

BÔMES / BOOMS	F36	F60	F125	F220	F550	F810	F1700
Point d'amure Tack stand off Tack down	A	40	40	40	50	50	55
	C	70	70	70	85	85	80
Cros de ris Reefing hook	B	45	35	35	40	40	55
	D	50	40	40	45	45	60
Entrée de ralingue Foot groove entry	E	130	130	130	170	180	245



- Bômes & options
- Bomes custom
- Prises de ris continues
- Bômes pour enrouleur de GV



- Booms & options
- Custom booms
- Single line reefing system
- Booms for furling masts



Prises de ris continues

Single line Reefing system

■ Facilité de manœuvre : avec le système prise de ris continue Sparcraft, un seul membre d'équipage peut prendre un ris en moins de 30 secondes

■ Easy system : with Sparcraft's single line reefing system, one sailor working from the cockpit can reef a sail in under 30 seconds

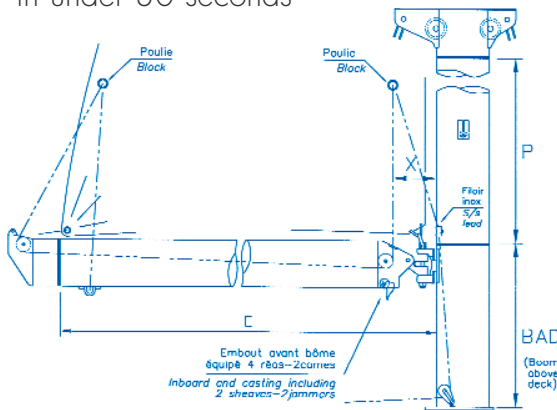

Pièces de bômes / Boom fittings

■ Chariots de point d'écoute de grand-voile & pour bôme à enrouleur de GV, coupleurs en inox pour chariots...

■ Main outhaul car and Outhaul car for furling boom, Stainless coupling for Sparcraft outhaul cars...

■ Balcons de bômes

■ Boom brackets

■ Différentes options de vit de mulet, réas, cames, embouts avant et arrière,...

■ Different options of goosenecks, sheaves, cams, inboard and outboard castings

Bômes pour mâts enrouleur

Booms for furling masts

■ Tous nos profils peuvent être équipés pour les mâts enrouleurs (chariots de bômes en direct, ou adaptés sur rails pour les plus gros profils)

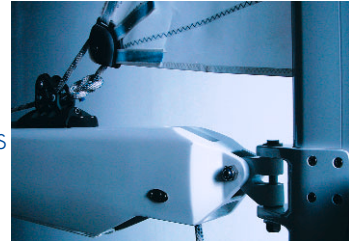

■ All Sparcraft boom sections are available for furling masts. Outhaul cars are mounted in or on top using tracks.



Bômes spéciales / Special booms

■ Bômes avec monte-charge rétractable

■ Booms with extension systems

■ Bômes rétreintes

■ Tapered booms



Bômes Custom / Custom booms

■ Bômes type canoë

■ Canoe booms

■ Bômes type Park Avenue

■ Park Avenue booms

■ Bômes composite pour la course

■ Composite booms for racing

